

■ 套管配件---塑料调节螺栓组件

■ Conduit Fittings---Plastic Adjusting Screw Assembly

项目编号 Item No.	418350
材料 Material	尼龙 Nylon-Black

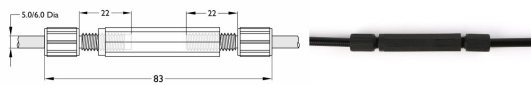

■ 套管配件---金属调节螺栓组件

■ Conduit Fittings---Metal Adjusting Screw Assembly

项目编号 Item No.	318360
材料 Material	镀锌钢 Znchickel plated steel

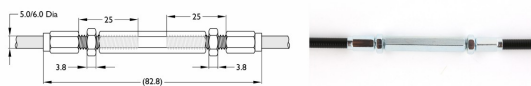

■ 套管配件---金属调节螺栓组件

■ Conduit Fittings---Metal Adjusting Screw Assembly

项目编号 Item No.	314750
材料 Material	镀锌钢 Znchickel plated steel

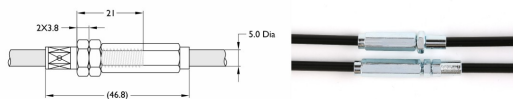

- ◆ 上面3种螺栓调节组件均用于增加管长 (L) 来减短行程 (A+B) 的作用;
- ◆ 用于产品长度较长且行程A+B要求较高的产品;
- ◆ A+B长度设计时需稍偏大, 才能起到调节作用。

- ◆ The above 3 adjust screws are used in increasing the tube length (L) to decrease the travel (A+B).
- ◆ Used for strict travel requirement products.
- ◆ The adjust screw can adjust when travel(A+B) is longer.

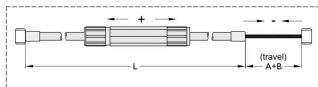

■ 套管配件---连接体

■ Conduit Fittings---Connectors

项目编号 Item No.	291361
材料 Material	铝 aluminium

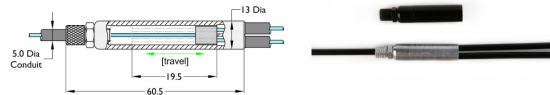

项目编号 Item No.	291377
材料 Material	铝 aluminium

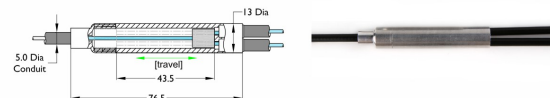

- 套管末端配件---塑料侧卡帽
- Conduit End Fittings---Side Snap-in Clips

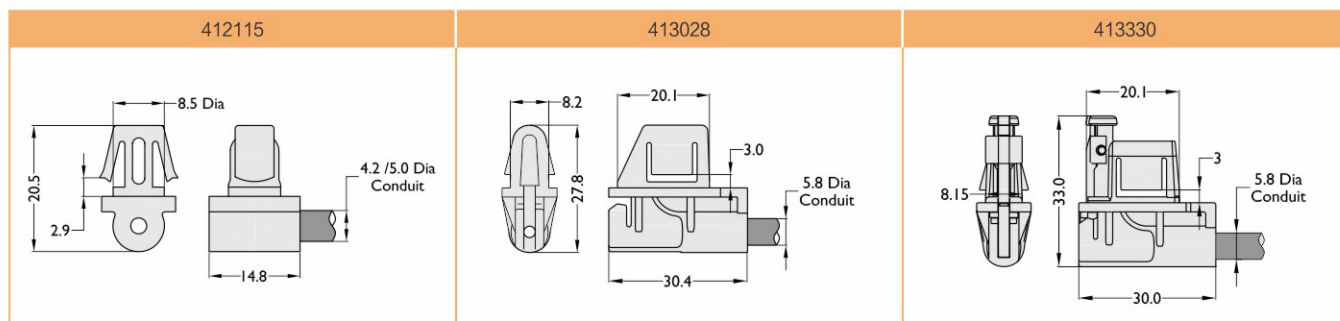
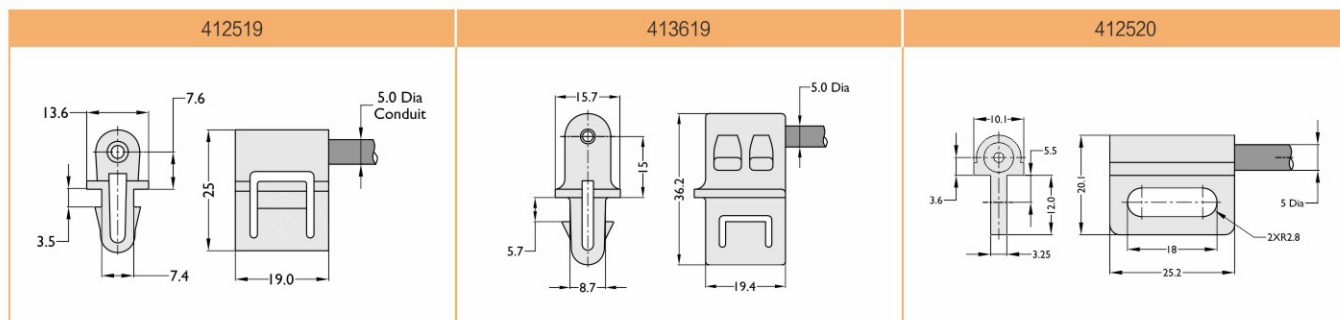

- 套管末端配件---直卡帽
- Conduit End Fittings---Straight Clips

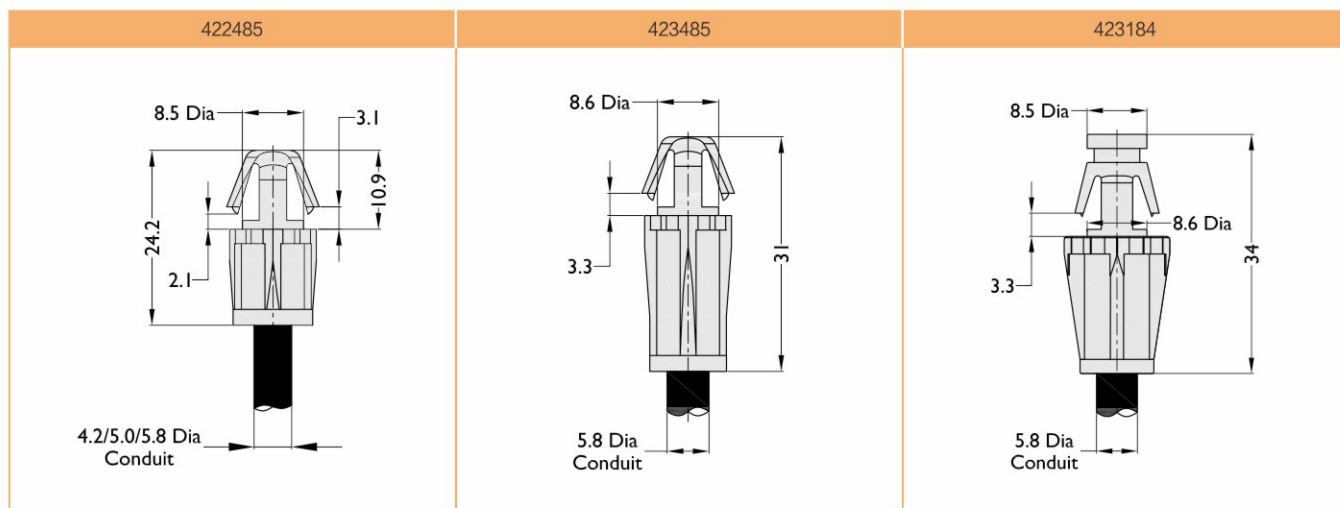

- 套管末端配件---四方帽
- Conduit End Fittings---Square Ends

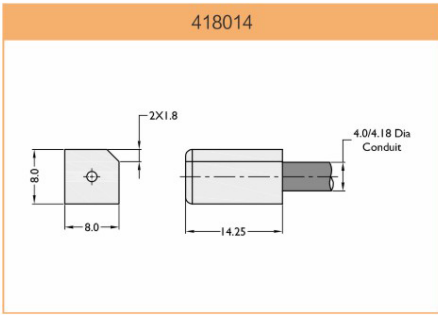

- 套管末端配件---支架
- Conduit End Fittings---Holder

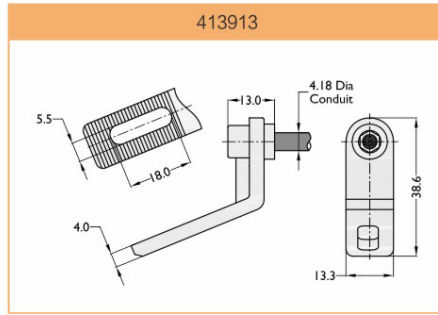

- 套管末端配件---C形卡座
- Conduit End Fittings---"C" Blocks

